



M1200 REMOTEST

OPTIONAL COPPER BYPASS DRAIN LINE

INSTALLATION INSTRUCTIONS

NOTE: You have ordered your M1200 REMOTEST with the Optional Copper Bypass Drain Line. In order to avoid potential damage in shipment, the Copper Drain Line has not yet been installed. It is recommended that the installation of the drain line be delayed until completion of riser and branch lines.

- Prior to installing the **M1200 REMOTEST TESTANDRAIN** valve into the "Floor Control Assembly" confirm that enough space exists to the "Right" and "Below" the **M1200** Valve to accommodate the installation of the optional drain line (refer to chart).
- Proceed with valve installation as normal per the installation instructions included with the valve. Sprinkler system can be pressure tested without the drain loop installed by leaving the plugs in **M1200** Valve Body inlet, and **M1200** Solenoid Valve outlet.
- Remove plugs and, using an appropriate sealant, install 1" NPT x Compression into the Solenoid of the **REMOTEST** outlet and 3/4" x Compression into the **M1200** Valve Body inlet.
- Remove the compression nuts and rings. Holding the copper line up against the **REMOTEST**, mark and cut (using a tube cutter to insure a smooth, round cut) the copper drain ends to the required lengths.
NOTE: The Copper Drain Line is purposely shipped long to allow for the variances created by the compression fittings being threaded to different depths.
- Slip compression nuts followed by compression rings onto drain line end. Position drain line into Solenoid outlet compression fitting, and Valve Body inlet compression fitting. Tighten compression nuts onto fittings.

M1200 REMOTEST OPTIONAL COPPER BYPASS DRAIN LINE INSTALLATION INSTRUCTIONS (contd.)

OPTIONAL BYPASS LOOP PLAN VIEW

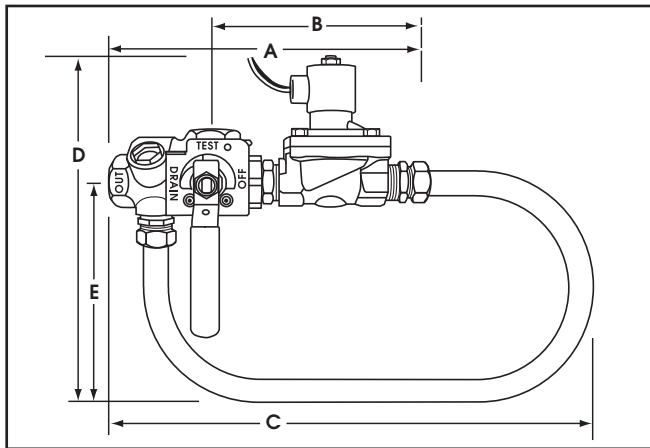

DIMENSIONS

SIZE	A	B	C	D	E
1"	9 1/2" 241.3mm	6 1/4" 158.8mm	18 1/2" 470mm	12 3/4" 323.9mm	8 3/4" 222.3mm
1 1/4"	10" 254mm	6 1/2" 165.1mm	18 1/2" 470mm	12 3/4" 323.9mm	8 3/4" 222.3mm
1 1/2"	11" 279.4mm	7 1/4" 184.2mm	18 1/2" 470mm	12 3/4" 323.9mm	8 3/4" 222.3mm
2"	11" 279.4mm	7 1/4" 184.2mm	18 1/2" 470mm	12 3/4" 323.9mm	8 3/4" 222.3mm

Note: Dimensions rounded up to nearest 1/4".



AGF Manufacturing Inc.
100 Quaker Lane, Malvern, PA 19355

T: (610) 240-4900 / F: (610) 240-4906
Email: info@testandrain.com
Web: www.testandrain.com



MADE IN U.S.A.

Reliability, Versatility, Code Compatibility

© REMOTEST and TESTANDRAIN are registered trademarks of AGF

JOB NAME: _____

ARCHITECT: _____

ENGINEER: _____

CONTRACTOR: _____