

Model ZW5000, ZW5000G, ZW5000F ZW5004, ZW5004G

WILKINS®

Pressure-Tru® 2 1/2" Field Adjustable Pressure Reducing (Regulating) Valve
Angle Bodies, Grooved or Threaded

Installation Testing Maintenance Instructions

Model ZW5000 Series (Hose Valve)

APPLICATION:

The ZW5000 Series Pressure Reducing Valves are UL® Listed and C-UL® Listed as standpipe valves for CLASS I and CLASS III systems.

SPECIFICATIONS:

- Regulates pressure under both flow and no-flow conditions
- Field adjustable
- Rated up to 400 psi inlet pressure
- Available with cap and chain
- Tapped and plugged inlet and outlet for pressure gauge
- Standard body, FNPT inlet x male NH hose outlet
- G option, grooved inlet x male NH hose outlet
- F option, FNPT inlet x FNPT outlet

Model ZW5004 Series (Floor Control Valve)

APPLICATION:

The ZW5004 Series Pressure Reducing Valve is UL® Listed and C-UL® Listed as a floor control valve in automatic sprinkler systems as well as a standpipe valve for CLASS I and CLASS III systems.

SPECIFICATIONS:

- Regulates pressure under both flow and no-flow conditions
- Field adjustable
- Rated up to 400 psi inlet pressure
- Open-Close indicating feature
- Can be adjusted in the field
- Built-in automatic checking device (NFPA Standard)
- Regulates pressure under both flow and no-flow conditions
- 2½" female inlet and outlet connections
- Integral supervisory switch
- Tapped and plugged inlet and outlet for pressure gauges
- Standard body, FNPT inlet x FNPT outlet
- G option, grooved inlet x outlet

INSTRUCTIONS

1. Flush pipe thoroughly to remove any debris, rust or scale that will foul and could damage seal ring or seat.
2. Install valve with arrow pointing in direction of flow. Only use hex on body connections as wrench surface. Wet systems: Valves may be installed in any position. Dry Systems: Install valve within 45 degrees of vertical, hand wheel up, slope inlet piping minimum 1/4 inch per foot to drain excess water to riser after testing.
3. After installation, initial testing must be done with design inlet pressure and flow rate so the proper outlet pressure can be verified. The valve shall be full flow tested in accordance with NFPA 13 and/or NFPA 14 and then tested periodically thereafter in accordance with NFPA 25; flow enough water annually to completely flush rust and debris, full flow test every five years.
4. Valves installed in sprinkler systems shall have:
 - a) Unions or rubber gasket fittings installed immediately upstream or downstream to permit replacement. Grooved bodies are sufficient.
 - b) A relief valve of at least 1/2" size and 175 psi max. installed on the downstream side and plumbed to a safe drainage, see Wilkins Model P4000A.
 - c) Pressure gauges installed on the inlet and outlet.
 - d) Shall not be set for less than 50 psi. Reference 8b below.
5. It is suggested that a line size Tee connection be installed downstream of sprinkler system valves to allow full flow testing as required every five years by NFPA 25.
6. Bleed all trapped air from supply riser and at remote points of sprinkler system piping when filling by installing an approved air release valve at high points of piping. Trapped air may cause outlet pressure fluctuations at low flows.
7. On dry systems, it is recommended to use Pressure Reducing Valves (PRV's) only in semiautomatic dry systems. If used in automatic dry systems, the system must be designed in such a manner that all excess water properly drains to the riser and the valve must be installed vertically to reduce the amount of pipe corrosion near the valve seat due to standing water (reference step #2 above). Hand wheel operation does not force the internal pressure reducing stem to open on all PRV's, and excess pipe corrosion near the valve seat can cause the PRV stem not to operate freely and potentially prevent the automatic dry system from triggering. Ensure system design conforms to all requirements of local Authority Having Jurisdiction (AHJ). Nitrogen fill systems are recommended with all dry systems to reduce the amount of corrosion in all system components.
8. For Class I & Class III Standpipe Systems:
 - a) The outlet pressures indicated in the residual pressure charts on pages 2-3 are at the outlet of the valve. To determine the pressure at a specific hose nozzle, the hydraulic calculation information provided in NFPA 13 and the NFPA Fire Protection Handbook, should be followed. In all cases, the design flow demand required from the hose nozzle shall not exceed the flow range specified in the residual pressure charts on pages 2-3.
 - b) The valve may be adjusted to provide residual pressures less than 100 psig (689 kpa), when permitted by the AHJ but not lower than 65 psig (448 kpa).

WARNING: This product is NOT Lead Free in accordance with U.S. Federal Law and is illegal in the U.S. for use in potable services or to install in water systems anticipated for human consumption.

⚠ **WARNING:** Cancer and Reproductive Harm - www.P65Warnings.ca.gov
⚠ **ADVERTENCIA:** Cáncer y daño reproductivo - www.P65Warnings.ca.gov
⚠ **AVERTISSEMENT:** Cancer et néfastes sur la reproduction - www.P65Warnings.ca.gov

Residual Pressure Charts

For Pressure-Tru® 2 1/2" Models

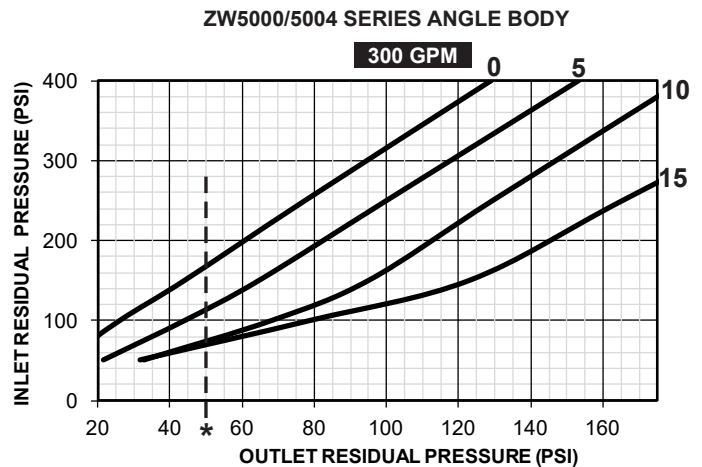
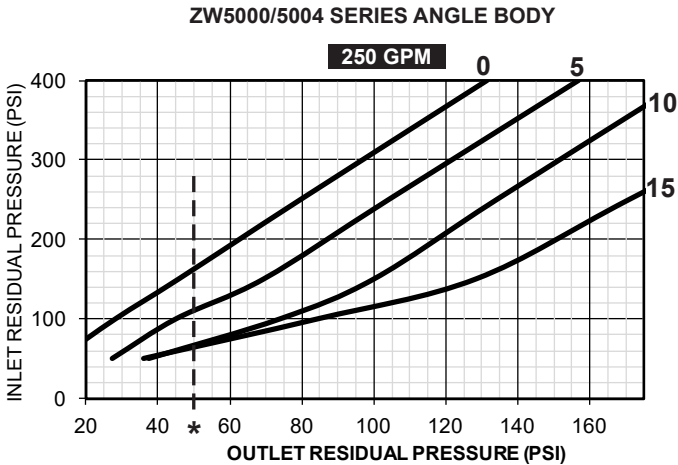
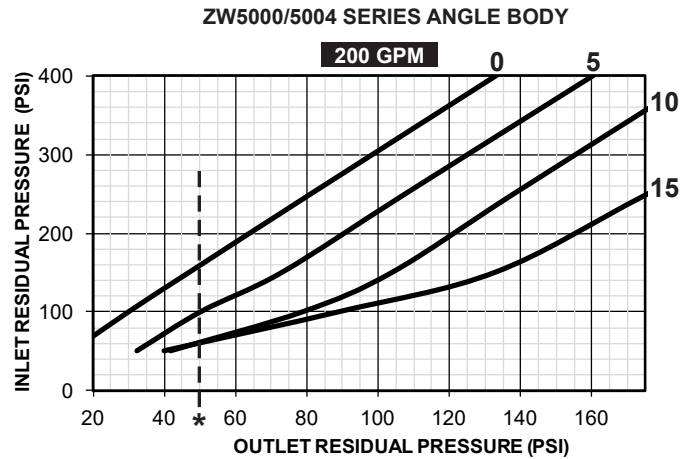
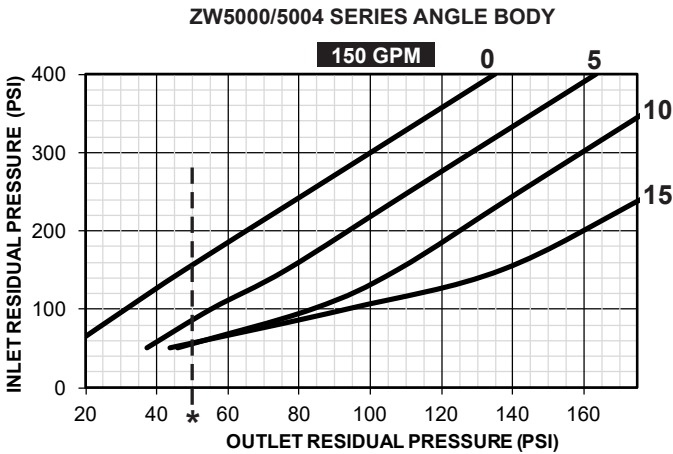
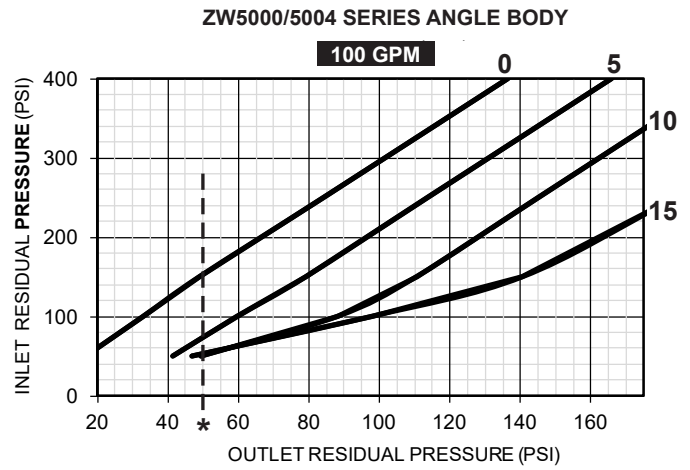
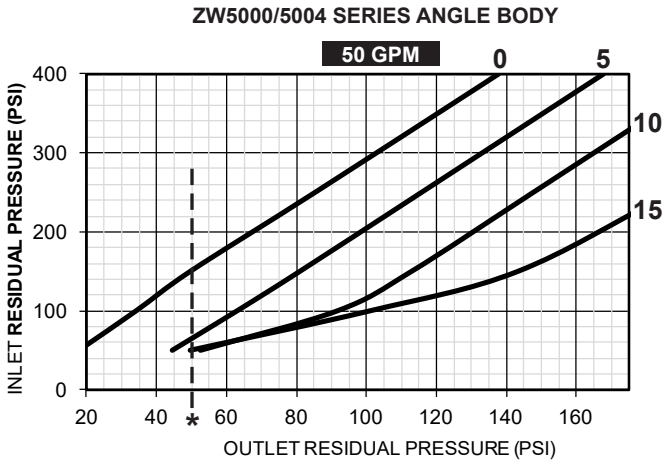

Note: Curve accuracy= ± 5 PSIG *50 PSI Minimum setting for sprinkler systems

Residual Pressure Charts

For Pressure-Tru® 2 1/2" Models

ZW5000/5004 SERIES ANGLE BODY

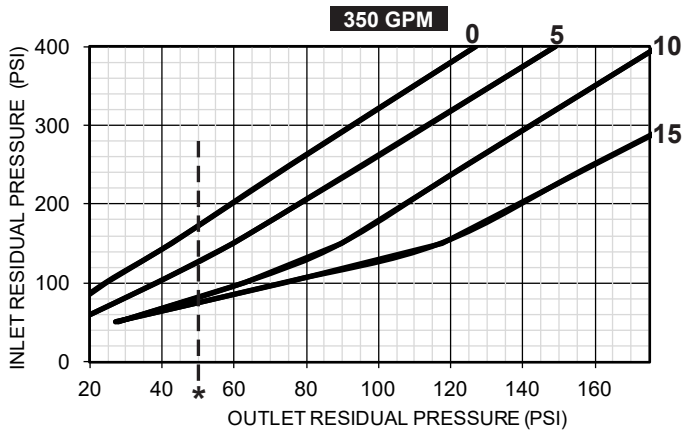

ZW5000/5004 SERIES ANGLE BODY

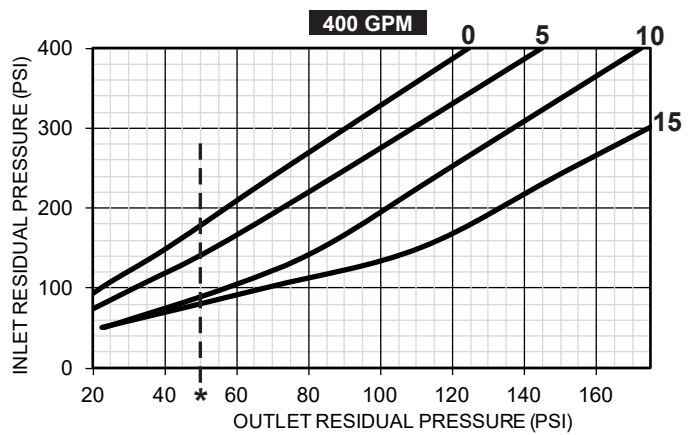

ZW5000/5004 SERIES ANGLE BODY

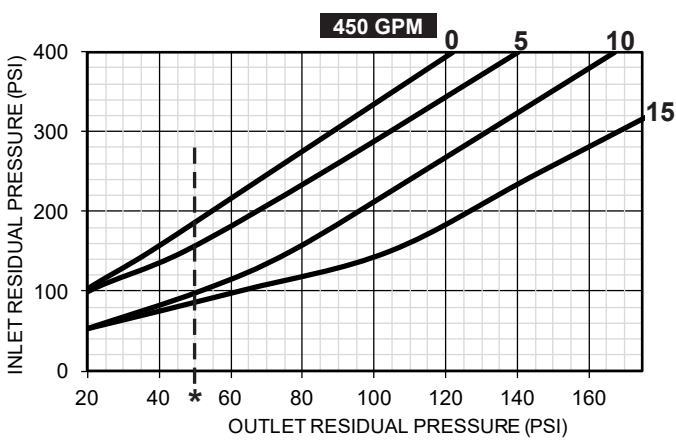

ZW5000/5004 SERIES ANGLE BODY

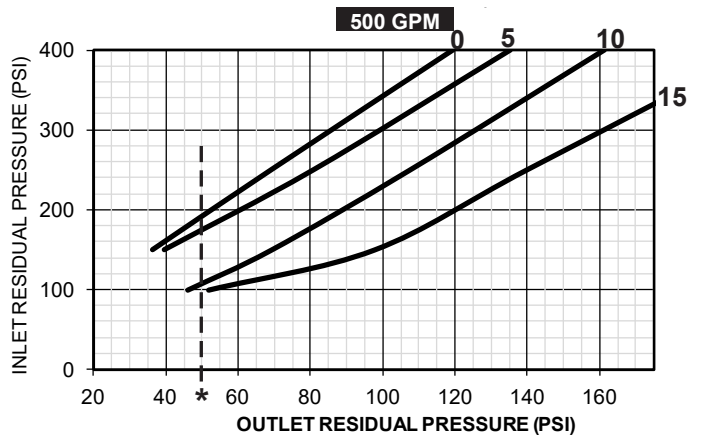

STATIC PRESSURE CHART

For Pressure-Tru® Angle
and In-line Valves
(2-1/2" Inlet and Outlet)

MODELS:
ZW5000 and ZW5004 (ALL)

ZW5000 SERIES
STATIC

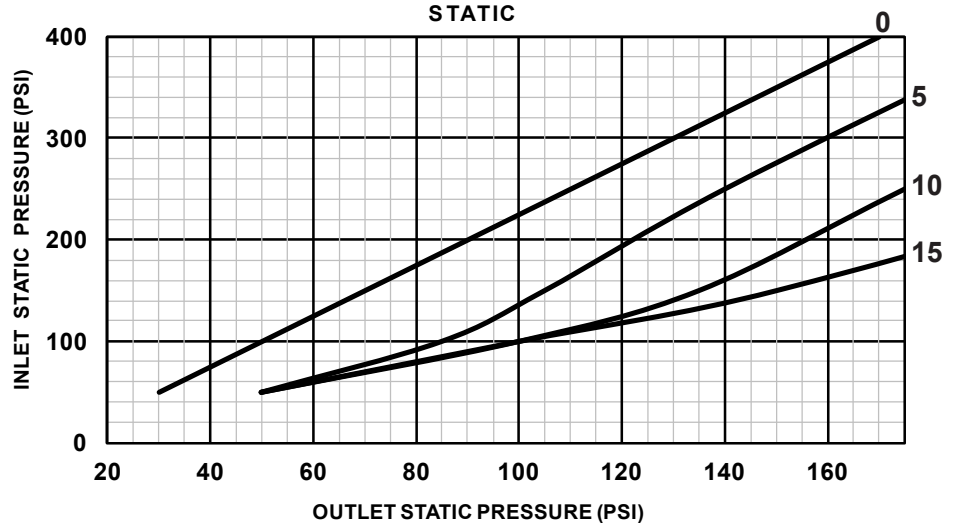

Note: Curve accuracy= ±5 PSIG *50 PSI Minimum setting for sprinkler systems

FIELD SETTING INSTRUCTIONS

1. Pressure gauges should be installed upstream and downstream (or in the tappings provided on the inlet and outlet) of the Pressure-Tru® Valve.
2. Refer to residual pressure charts on pages 2-3 to determine the proper setting.
3. Open valve by rotating hand wheel in direction of "OPEN" arrow on hand wheel.
4. If applicable remove tamper proof shield by removing the two screws using a 5/32" hex wrench. Move proof shield toward body to access adjusting nut.
5. Insert the 3/8" diameter adjusting rod (included with the valve) into a hole on the adjusting nut. Rotate the adjusting nut to increase or decrease the setting. Decreasing the setting number lowers the downstream pressure (See Fig. 2). One full turn of the adjusting nut results in one setting number change (See Fig. 1)
6. See Fig. 2 Increase spring load to increase the setting and decrease spring load to reduce the setting. Decreasing the setting lowers the downstream pressure. One full turn of the adjusting nut is one setting number adjustment (Fig. 1)

NOTE: Do not exceed 175 PSI static (maximum setting of 15)

7. After adjusting, the valve shall be tested in accordance with NFPA 14 and tested periodically thereafter in accordance with NFPA 25 (see page 1 Instructions, item 3 for further testing requirements)

CHOOSING THE CORRECT SETTINGS

In designing a sprinkler system, a minimum of 20 psi pressure differential (the difference between the inlet static pressure and the valve outlet set static pressure) is recommended to assure a well regulated and efficient system. In choosing the correct setting for the Pressure-Tru® valve, refer to the Residual Pressure Charts, Static Pressure Chart and the following procedures:

1. Determine the standpipe residual or pressure under flowing conditions at the valve inlet.
2. Determine the demand in gallons per minute required downstream of the valve.
3. Locate the appropriate flow chart based on GPM required, valve type and size.
4. Locate the inlet residual pressure on the vertical axis of the chart and draw a horizontal line from this pressure across the chart.
5. Locate the desired valve outlet residual pressure on the horizontal axis of the chart and draw a vertical line from this pressure.
6. The curve nearest the intersection of the two lines drawn is the appropriate setting for the valve.
7. To determine the static outlet pressure, locate the static chart for the appropriate valve size. Determine the valve inlet static pressure shown on the vertical axis and draw a horizontal line from that pressure to the appropriate curve determined above, then draw a vertical line down to them horizontal axis and read the static outlet pressure.

Proper performance is dependent upon licensed, qualified personnel performing regular, periodic testing according to WILKINS' specifications and prevailing governmental & industry standards and codes and upon following these installation instructions. Failure to do so releases WILKINS of any liability that it might otherwise have with respect to that device. Such failure could also result in an improperly functioning device.

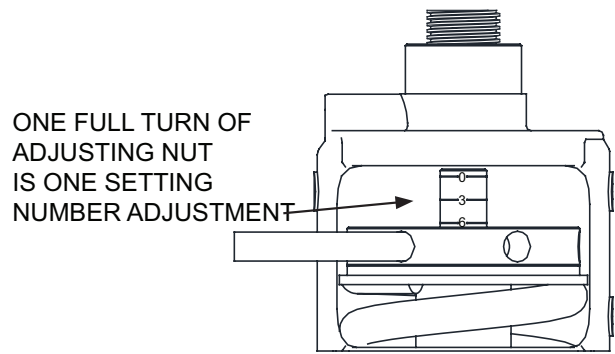

(Fig. 1)

CAUTION: To prevent a false reading during the setting process it is necessary that a test valve be opened and closed to relieve the locked up pressure in the system.

If the system requires the valve to remain in a static position to maintain a regulated dead-end service pressure, it is good engineering practice to incorporate a pressure relief valve within the system.

VALVES WHICH ARE FIELD SET DIFFERENT THAN ABOVE INSTRUCTIONS WILL RENDER THE WARRANTY VOID.

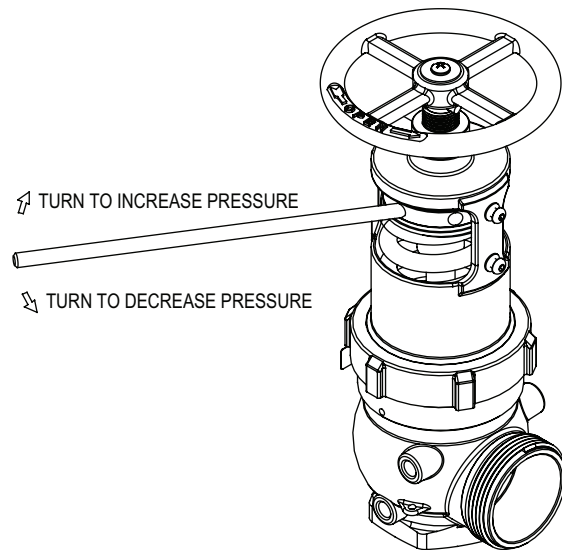

(Fig. 2)

VALVE CARE AND MAINTENANCE

Since the Pressure-Tru® Valve is an automatic valve, it is imperative to make sure that the system is free of rocks and debris. This can be ensured by flushing the system. Upon completion of valve installation and testing, it is important that it be filled slowly to prevent water hammer. It is recommended that a flow test be run periodically to allow the Pressure-Tru® Valve to open and reset itself. If valve repair is required, the system should be drained. Access to internal components can be achieved by removing the wheel handle assembly, adjusting nut, spring, bell housing and flange. The body need not be removed from the system. Contact the factory for repair parts.